

1

2

3

4

版本REV

繪制日期

A

2009-3-27

A

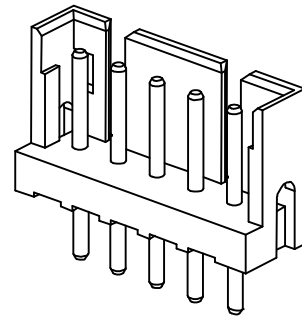
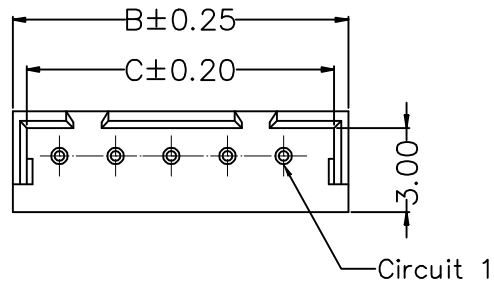

B

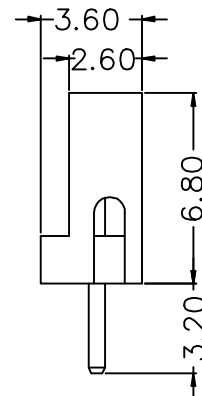
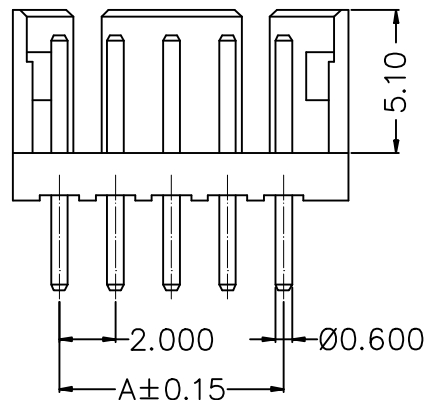

C

02P~15P Double Gap

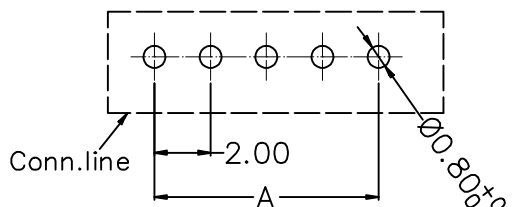

Recommended P.C.B Layout  
General Tolerance±0.05

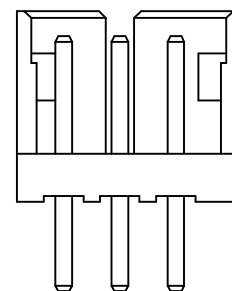

02P~03P Single Gap

D

NOTE:

- Welding Board Angle: V-Straight 180°
- Material: NYLON 66 UL 94V-0
- Material(Pin): Brass
- Finish(Pin): Tin-Plating
- Row No.-Pin No.: NP-2P~15P
- Plug the Pin & Special No.: Without Kink ;

Poles	Dimensions (mm)			Poles	Dimensions (mm)		
	A	B	C		A	B	C
02	2.00	5.96	4.96	09	16.00	19.96	18.96
03	4.00	7.96	6.96	10	18.00	21.96	20.96
04	6.00	9.96	8.96	11	20.00	23.96	22.96
05	8.00	11.96	10.96	12	22.00	25.96	24.96
06	10.00	13.96	12.96	13	24.00	27.96	26.96
07	12.00	15.96	14.96	14	26.00	29.96	28.96
08	14.00	17.96	16.96	15	28.00	31.96	30.96

E

一般公差: GENERAL TOLERANCE

更改說明: REV. DESCRIPTION

更改說明: REV. DESCRIPTION

尺寸範圍DIM



10.01以上之尺寸

±0.20



10.00以內之尺寸

±0.15



孔位

±0.10

核准APPD

朱小华

2009-3-27

模型:

料號: ITEM NO

文件編號

審核CHD

MODEL

A2004WV-00-NP

SC-EW-11

繪圖DWN

Liaozting

2009-3-27

比例: SCALE



SHIH CHUAN ELECTRONICS

規格: SPEC

2.00mm Crimp Style Connectors

1

2

3

4

版本REV

繪制日期

A

2009-3-27

A

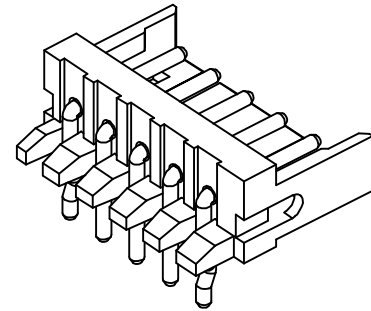

B

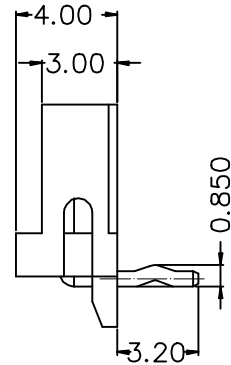
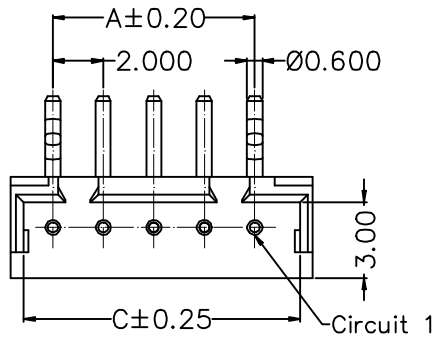

C

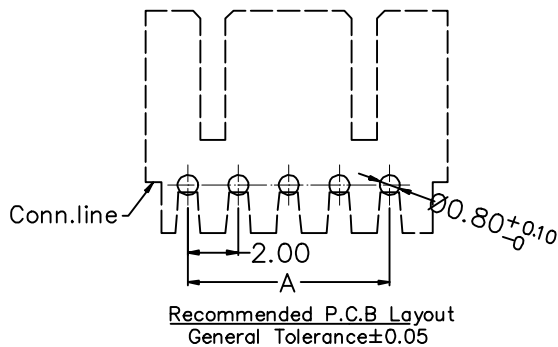
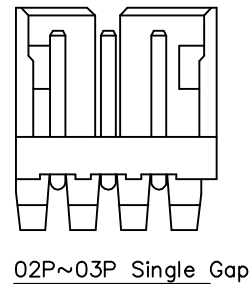
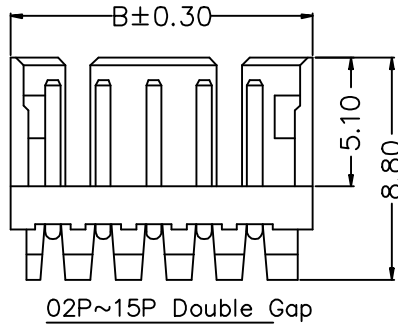

D

NOTE:

- Welding Board Angle: R- Right Angle 90°
- Material: NYLON 66 UL 94V-0
- Material(Pin): Brass
- Finish(Pin): Tin-Plating
- Row No.-Pin No.: NP-2P~15P

Poles	Dimensions (mm)			Poles	Dimensions (mm)		
	A	B	C		A	B	C
02	2.00	5.96	4.96	09	16.00	19.96	18.96
03	4.00	7.96	6.96	10	18.00	21.96	20.96
04	6.00	9.96	8.96	11	20.00	23.96	22.96
05	8.00	11.96	10.96	12	22.00	25.96	24.96
06	10.00	13.96	12.96	13	24.00	27.96	26.96
07	12.00	15.96	14.96	14	26.00	29.96	28.96
08	14.00	17.96	16.96	15	28.00	31.96	30.96

E

一般公差: GENERAL TOLERANCE

更改說明: REV. DESCRIPTION

更改說明: REV. DESCRIPTION

尺寸範圍DIM



10.01以上之尺寸

±0.20



10.00以內之尺寸

±0.15



孔位

±0.10

核准APPD

朱小华

2009-3-27

模型:

料號: ITEM NO

文件編號

審核CHD

MODEL

A2004WR-00-NP

SC-EW-11

繪圖DWN

Liaozting

2009-3-27

比例: SCALE



SHIH CHUAN ELECTRONICS

規格: SPEC

2.00mm Crimp Style Connectors

A	1	2	3	4
				版本REV A

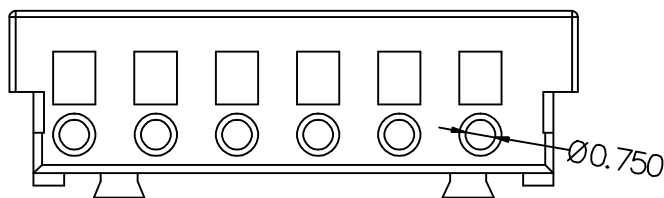
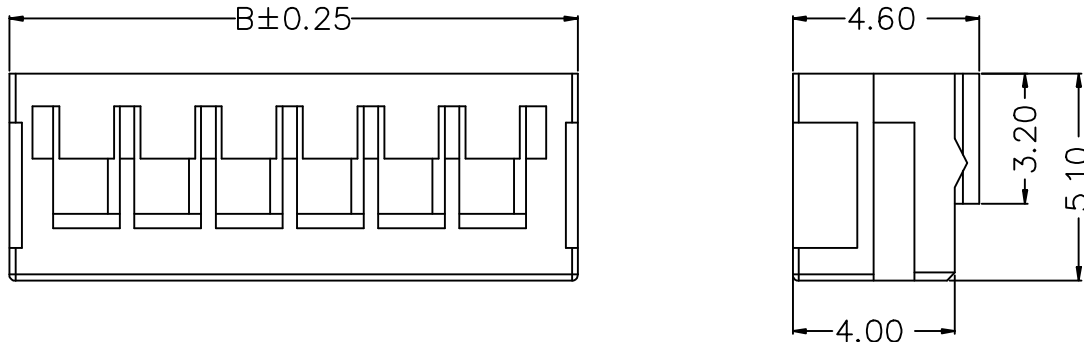
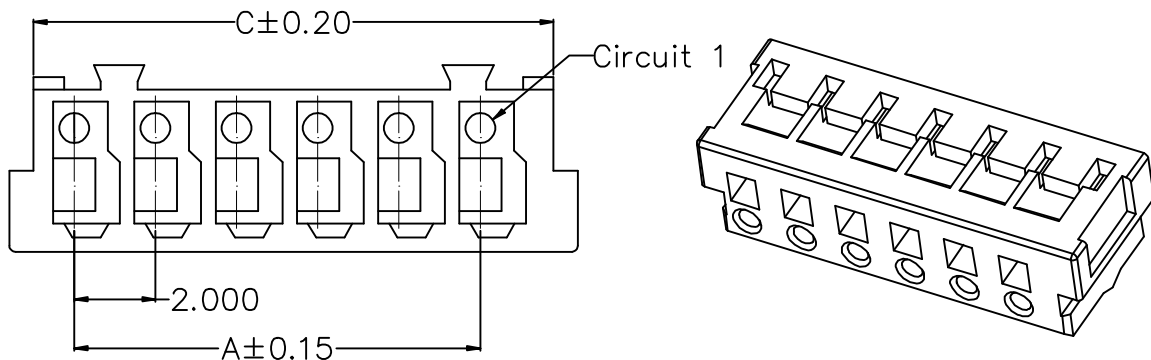

D NOTE:

- Material: PA66 94V-0
- Poles: 2P~15P

Poles	Dimensions (mm)			Poles	Dimensions (mm)		
	A	B	C		A	B	C
02	2.00	6.00	4.80	09	16.00	20.00	18.80
03	4.00	8.00	6.80	10	18.00	22.00	20.80
04	6.00	10.00	8.80	11	20.00	24.00	22.80
05	8.00	12.00	10.80	12	22.00	26.00	24.80
06	10.00	14.00	12.80	13	24.00	28.00	26.80
07	12.00	16.00	14.80	14	26.00	30.00	28.80
08	14.00	18.00	16.80	15	28.00	32.00	30.80

E	一般公差:GENERAL TOLERANCE		更改說明:REV.DESCRPTION			更改說明:REV.DESCRPTION	
	尺寸範圍DIM		△			△	
	10.01以上之尺寸	±0.30	△			△	
	10.00以內之尺寸	±0.20	△			△	
	孔位	±0.10	核准APPD	朱小华	2009-3-27	模型: MODEL	料號: ITEM NO
	文件編號	SC-EW-11	審核CHD				A2004H-00-NP
比例: SCALE	 SHIH CHUAN ELECTRONICS				規格: SPEC 2.00mm Crimp Style Connectors		

1

2

3

4

版本REV	繪制日期
A	2009-3-27

A

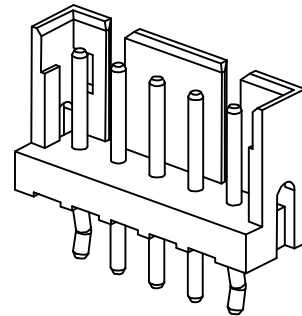
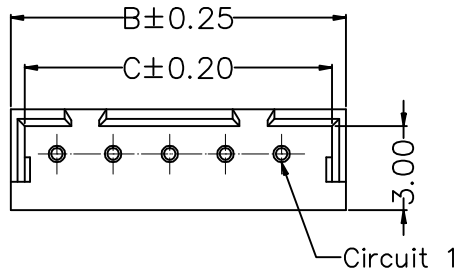

B

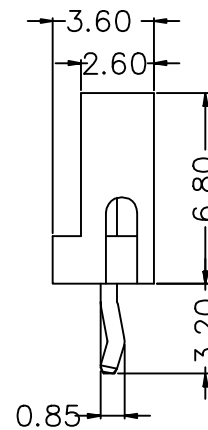
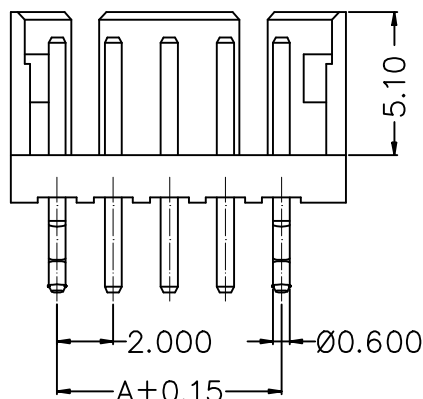

C

02P~15P Double Gap

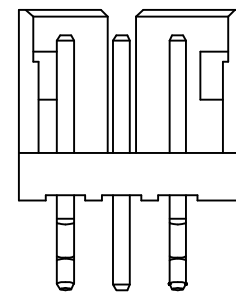
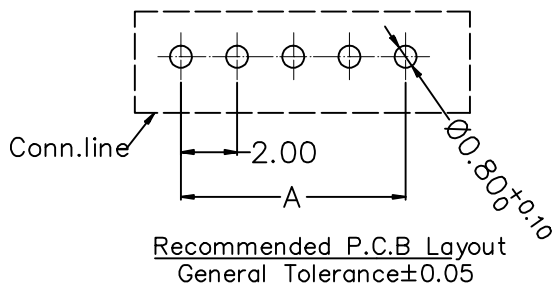

02P~03P Single Gap

D

NOTE:

- Welding Board Angle: V-Straight 180°
- Material: NYLON 66 UL 94V-0
- Material(Pin): Brass
- Finish(Pin): Tin-Plating
- Row No.-Pin No.: NP-2P~15P
- Plug the Pin & Special No.: K-With Kink ;

Poles	Dimensions (mm)			Poles	Dimensions (mm)		
	A	B	C		A	B	C
02	2.00	5.96	4.96	09	16.00	19.96	18.96
03	4.00	7.96	6.96	10	18.00	21.96	20.96
04	6.00	9.96	8.96	11	20.00	23.96	22.96
05	8.00	11.96	10.96	12	22.00	25.96	24.96
06	10.00	13.96	12.96	13	24.00	27.96	26.96
07	12.00	15.96	14.96	14	26.00	29.96	28.96
08	14.00	17.96	16.96	15	28.00	31.96	30.96

E

一般公差: GENERAL TOLERANCE

更改說明: REV. DESCRIPTION

更改說明: REV. DESCRIPTION

尺寸範圍DIM

①

④

10.01以上之尺寸

±0.20

②

⑤

10.00以內之尺寸

±0.15

③

⑥

孔位

±0.10

核准APPD

朱小华

2009-3-27

模型:

料號: ITEM NO

文件編號

審核CHD

MODEL

A2004WVK-00-NP

SC-EW-11

繪圖DWN

Liaozting

2009-3-27

比例: SCALE



SHIH CHUAN ELECTRONICS

規格: SPEC

2.00mm Crimp Style Connectors