

1

2

3

4

版本REV

繪制日期

A

2009-3-28

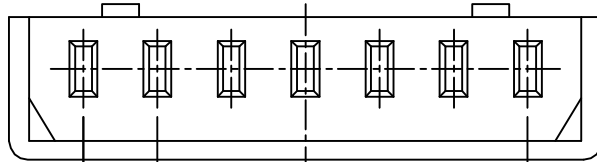
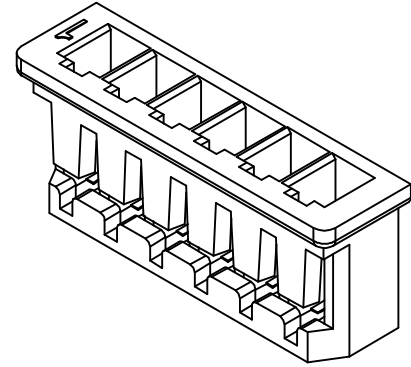

$2.00 \pm 0.10$   
 $A \pm 0.20$

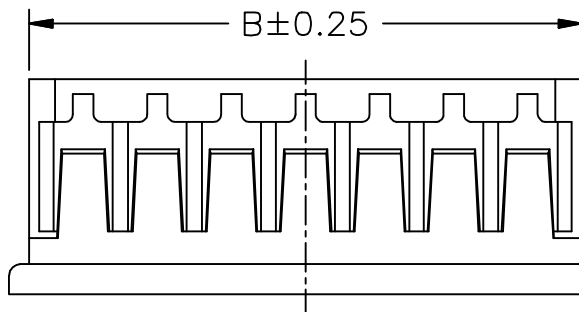

$B \pm 0.25$

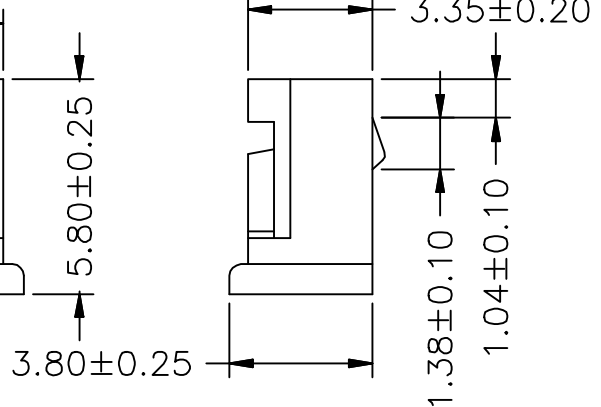

$3.80 \pm 0.25$

$3.35 \pm 0.20$

$1.38 \pm 0.10$

$1.04 \pm 0.10$

Circuit No.	Dimensions	
	A	B
02P	2.00	4.90
03P	4.00	6.90
04P	6.00	8.90
05P	8.00	10.90
06P	10.00	12.90
07P	12.00	14.90
08P	14.00	16.90
09P	16.00	18.90
10P	18.00	20.90
11P	20.00	22.90
12P	22.00	24.90
13P	24.00	26.90
14P	26.00	28.90
15P	28.00	30.90

NOTE:

- Material: PA66 94V-0
- Row No.-Pin No.: NP-2P-15P

一般公差: GENERAL TOLERANCE

更改說明: REV. DESCRIPTION

更改說明: REV. DESCRIPTION

尺寸範圍DIM

①

④

10.01以上之尺寸

 $\pm 0.20$ 

②

⑤

10.00以內之尺寸

 $\pm 0.15$ 

③

⑥

孔位

 $\pm 0.10$ 

核准APPD

朱小华

2009-3-28

模型:

料號: ITEM NO

文件編號

審核CHD

MODEL

A2008H00-NP

SC-EW-11

繪圖DWN

Liaozting

2009-3-28

比例: SCALE



SHIH CHUAN ELECTRONICS

規格: SPEC

2.00mm Crimp Style Connectors

1

2

3

4

版本REV

繪制日期

A

2009-3-28

A

Circuit 1

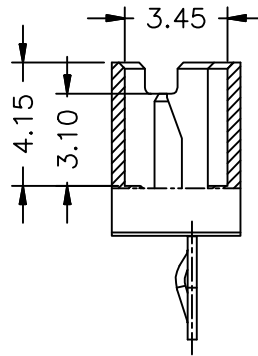
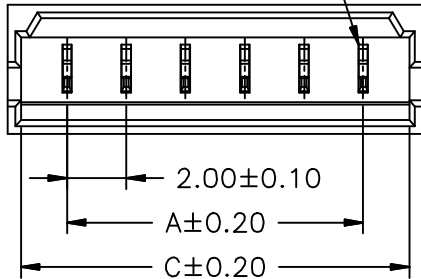

SEC:A-A

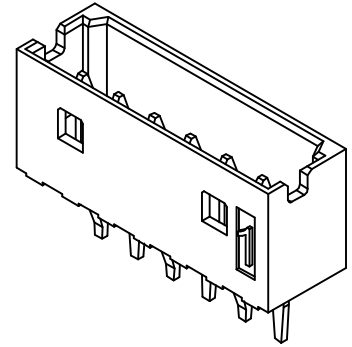

B

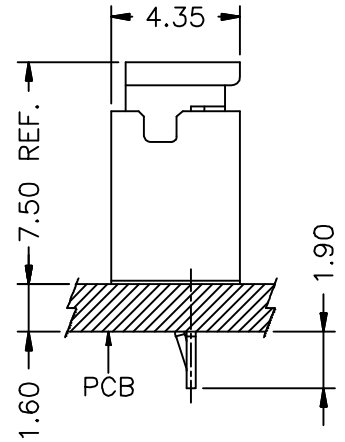
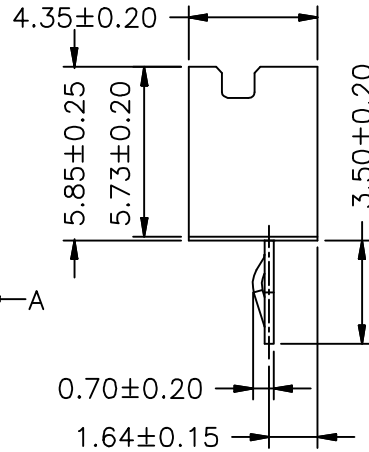
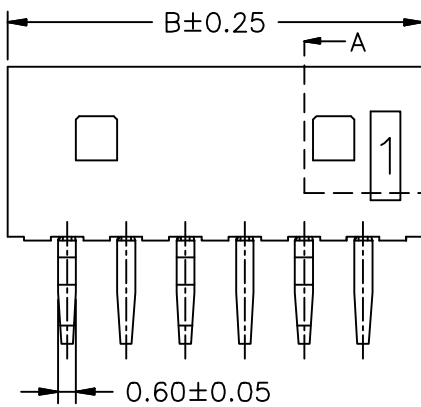

MATED CONDITION

C

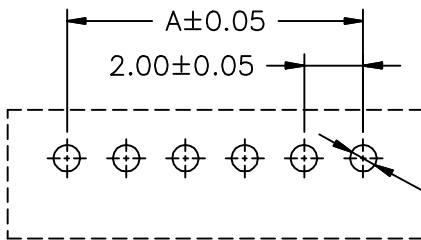

P.C.B. LAYOUT

D

NOTE:

- Welding Board Angle: V-Stright 180°
- Material: Nylon 66, UL94V-0
- Material(Pin): Phosphor Bronze
- Finish(Pin): Tin-plated
- Row No.-Pin No.: NP-02P-15P

Circuit No.	Dimensions		
	A	B	C
02P	2.00	6.00	5.10
03P	4.00	8.00	7.10
04P	6.00	10.00	9.10
05P	8.00	12.00	11.10
06P	10.00	14.00	13.10
07P	12.00	16.00	15.10
08P	14.00	18.00	17.10
09P	16.00	20.00	19.10
10P	18.00	22.00	21.10
11P	20.00	24.00	23.10
12P	22.00	26.00	25.10
13P	24.00	28.00	27.10
14P	26.00	30.00	29.10
15P	28.00	32.00	31.10

E

一般公差: GENERAL TOLERANCE

更改說明: REV. DESCRIPTION

更改說明: REV. DESCRIPTION

尺寸範圍DIM

①

④

10.01以上之尺寸

±0.20

②

⑤

10.00以內之尺寸

±0.15

③

⑥

孔位

±0.10

核准APPD

朱小华

2009-3-28

模型:

料號: ITEM NO

文件編號

審核CHD

MODEL

A2008WV00-NP

SC-EW-11

繪圖DWN

Liaozting

2009-3-28

比例: SCALE



SHIH CHUAN ELECTRONICS

規格: SPEC

2.00mm Crisp Style Connectors