

	1	2	3	4
--	---	---	---	---

版本REV	日期
A2	2017-8-18

A

B

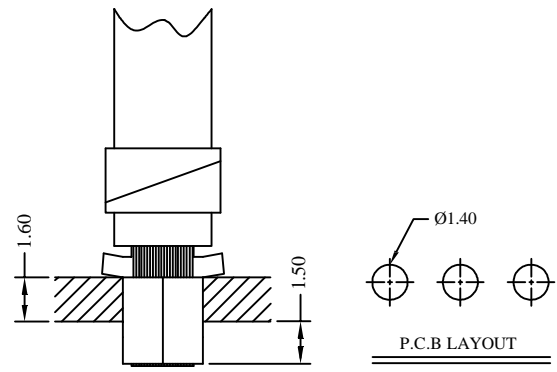
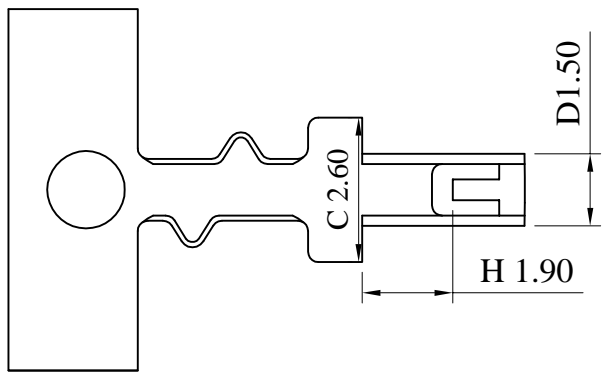

C

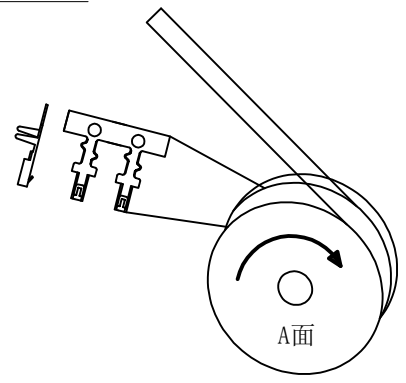
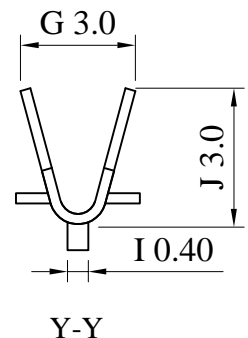
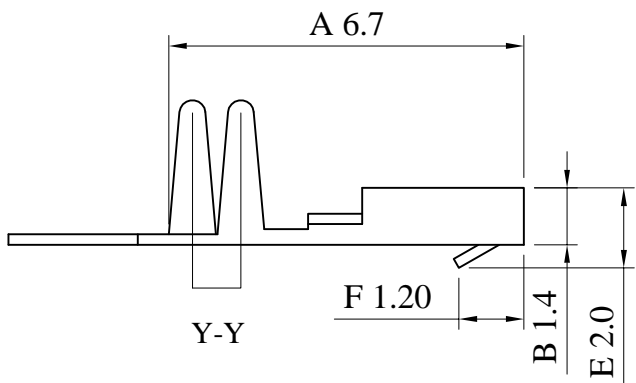

成品捲料方向. 如圖所示
端子头部朝A面, PVC包脚向上

D

NOTE:

- 1.THICKNESS: 0.20mm
- 2.MATERIAL: PHOSPHOR BRONZE
- 3.FINISH: TIN-PLATE 60 μ "以上
- 4.APPLICABLE WIRE: AWG18-24
- 5.P.C.BOARD HOLE: 1.40Ømm.
- 6.P.C.BOARD THICKNESS: 1.60mm
- 7.STANDARD PACKING:10000PCS/R
- 8.此产品符合RoHS指令要求

E

一般公差: GENERAL TOLERANCE		更改說明: REV.DESCRPTION			更改說明: REV.DESCRPTION	
尺寸範圍DIM		①			④	
.0	±0.20	②			⑤	
.00	±0.15	③			⑥	
.000	±0.10	核准APPD	朱小华	2017-8-18	模型:	料號: ITEM NO
文件編號		審核CHD	Tony	2017-8-18	MODEL	33093PS-2MT-T
SC-EW-11		繪圖DWN	廖政庭	2017-8-18		
比例: SCALE				規格: SPEC		
				P.C.B 1.4 Ø		