

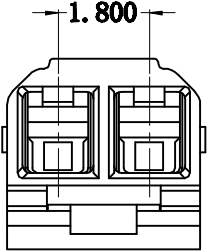
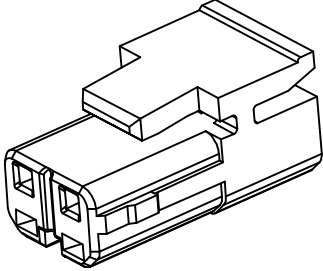
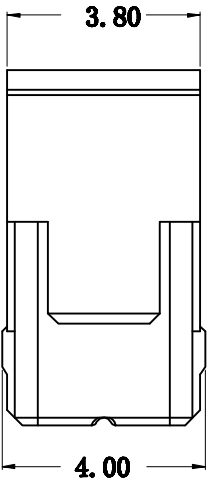
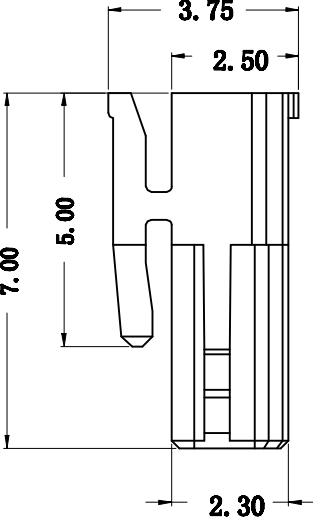
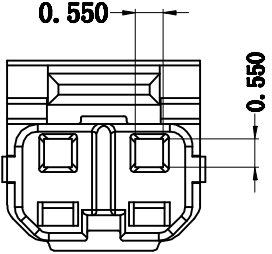

	1	2	3	4		
A				版本REV	繪制日期	
				A	2009-2-24	
B						
C						
D	<p>NOTE:</p> <ol style="list-style-type: none"> 1.THICKNESS: 0.20mm 2.MATERIAL: PHOSPHOR BRONZE 3.FINISH: TIN PIATED 4.APPLICABLE WIRE:AWG22-26 5.使用量具為電子卡尺 					
E	一般公差:GENERAL TOLERANCE		更改說明:REV.DESCRPTION		更改說明:REV.DESCRPTION	
	尺寸範圍DIM		△		△	
	.0	±0.30	△		△	
	.00	±0.20	△		△	
	.000	±0.10	核准APPD	朱小华	2009-2-24	模型: 料號: ITEM NO
	文件編號		審核CHD			
	SC-A-2001T		繪圖DWN	Liaozting	2009-2-24	MODEL A1801TOP-00
比例: SCALE					規格: SPEC 1.80mm Crimp Style Connectors	

	1	2	3	4																																																						
A				<table border="1"> <tr> <td>版本REV</td> <td>繪制日期</td> </tr> <tr> <td>A</td> <td>2009-3-27</td> </tr> </table>	版本REV	繪制日期	A	2009-3-27																																																		
版本REV	繪制日期																																																									
A	2009-3-27																																																									
B																																																										
C																																																										
D																																																										
E	<p>NOTE:</p> <ul style="list-style-type: none"> •Material: NYION PA66 94V-0 •ROW NO.-PIN NO: 02-02P •Special NO: B-Short body With Lock •HF-Halogen Free <table border="1"> <tr> <td colspan="2">一般公差:GENERAL TOLERANCE</td> <td colspan="2">更改說明:REV.DESCRPTION</td> <td colspan="2">更改說明:REV.DESCRPTION</td> </tr> <tr> <td colspan="2">尺寸範圍DIM</td> <td colspan="2">△</td> <td colspan="2">△</td> </tr> <tr> <td>10.01以上之尺寸</td> <td>±0.30</td> <td colspan="2">△</td> <td colspan="2">△</td> </tr> <tr> <td>10.00以內之尺寸</td> <td>±0.20</td> <td colspan="2">△</td> <td colspan="2">△</td> </tr> <tr> <td>孔位</td> <td>±0.10</td> <td>核准APPD</td> <td>朱小华</td> <td>2009-3-27</td> <td>模型: MODEL</td> </tr> <tr> <td>文件編號</td> <td>SC-EW-11</td> <td>審核CHD</td> <td></td> <td></td> <td>料號: ITEM NO</td> </tr> <tr> <td></td> <td></td> <td>繪圖DWN</td> <td>Liaozting</td> <td>2009-3-27</td> <td>A1801HB-00-02</td> </tr> <tr> <td>比例: SCALE</td> <td colspan="3"> </td> <td colspan="2">規格: SPEC</td> </tr> <tr> <td></td> <td colspan="3"></td> <td colspan="2">1.80mm Crimp Style Connectors</td> </tr> </table>				一般公差:GENERAL TOLERANCE		更改說明:REV.DESCRPTION		更改說明:REV.DESCRPTION		尺寸範圍DIM		△		△		10.01以上之尺寸	±0.30	△		△		10.00以內之尺寸	±0.20	△		△		孔位	±0.10	核准APPD	朱小华	2009-3-27	模型: MODEL	文件編號	SC-EW-11	審核CHD			料號: ITEM NO			繪圖DWN	Liaozting	2009-3-27	A1801HB-00-02	比例: SCALE				規格: SPEC						1.80mm Crimp Style Connectors	
一般公差:GENERAL TOLERANCE		更改說明:REV.DESCRPTION		更改說明:REV.DESCRPTION																																																						
尺寸範圍DIM		△		△																																																						
10.01以上之尺寸	±0.30	△		△																																																						
10.00以內之尺寸	±0.20	△		△																																																						
孔位	±0.10	核准APPD	朱小华	2009-3-27	模型: MODEL																																																					
文件編號	SC-EW-11	審核CHD			料號: ITEM NO																																																					
		繪圖DWN	Liaozting	2009-3-27	A1801HB-00-02																																																					
比例: SCALE				規格: SPEC																																																						
				1.80mm Crimp Style Connectors																																																						

A	1	2	3	4			
				<table border="1"> <tr> <td>版本REV</td> <td>繪制日期</td> </tr> <tr> <td>A</td> <td>2009-3-27</td> </tr> </table>	版本REV	繪制日期	A
版本REV	繪制日期						
A	2009-3-27						
B							
C							
D							
E	<p>NOTE:</p> <ul style="list-style-type: none"> •Material: NY10N PA66 94V-0 •ROW NO.-PIN NO: 02-02P •Plug the pin&Special NO: A-With Lock •HF-Halogen Free 						
	一般公差:GENERAL TOLERANCE		更改說明:REV.DESCRPTION		更改說明:REV.DESCRPTION		
	尺寸範圍DIM		△		△		
	10.01以上之尺寸	±0.30	△		△		
	10.00以內之尺寸	±0.20	△		△		
	孔位	±0.10	核准APPD	朱小华	2009-3-27	模型: MODEL	料號: ITEM NO
文件編號		審核CHD				A1801HA-00-02	
SC-EW-11		繪圖DWN	Liaozting	2009-3-27			
比例: SCALE	 SHIH CHUAN ELECTRONICS			規格: SPEC 1.80mm Crimp Style Connectors			

1

2

3

4

版本REV

繪制日期

A

2009-3-27

A

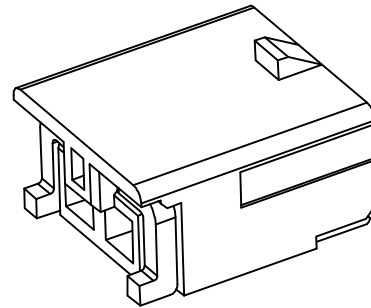
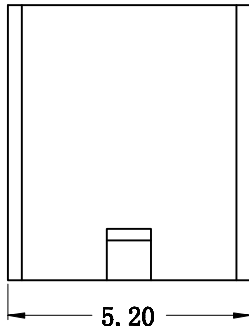

B

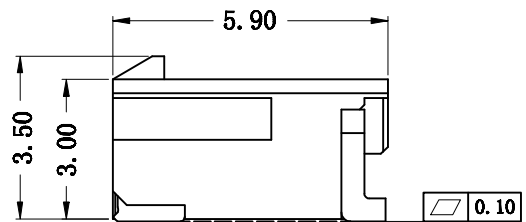
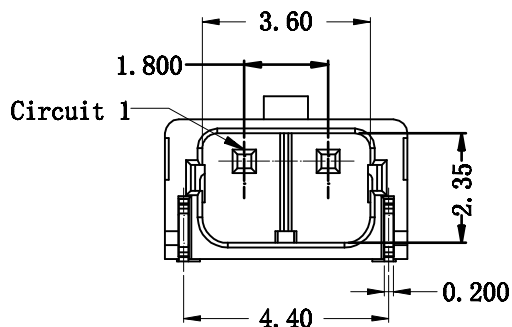

C

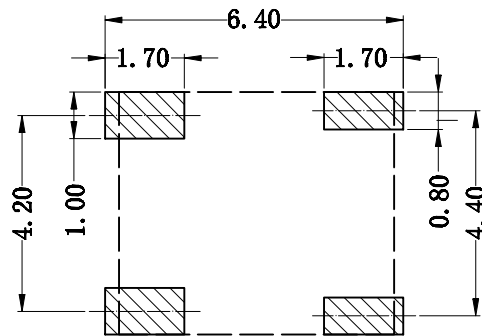
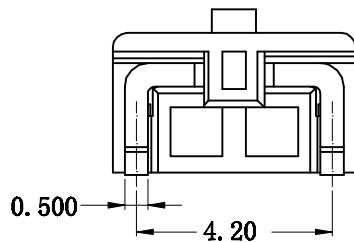
**Recommended P. C. B Layout**General tolerance ± 0.05

NOTE:

- Welding Board Angle: R- Right Angle 90°
- Welding Way: S-SMT
- Row No.-Pin No.: 02-02P
- Plug the Pin & Special No.: A-With Lock
- Material: LP-LCP 94V-0
- Material(Pin): Brass
- Finish(Pin): Matee Tin-Plating

D

E

一般公差: GENERAL TOLERANCE

更改說明: REV. DESCRIPTION

更改說明: REV. DESCRIPTION

尺寸範圍DIM



10.01以上之尺寸

 ± 0.20 

10.00以內之尺寸

 ± 0.15 

孔位

 ± 0.10

核准APPD

朱小华

2009-3-27

模型:

料號: ITEM NO

文件編號

審核CHD

MODEL

A1801WR-00-02

SC-EW-11

繪圖DWN

Liaozting

2009-3-27

比例: SCALE



SHIH CHUAN ELECTRONICS

規格: SPEC

1.80mm Crimp Style Connectors

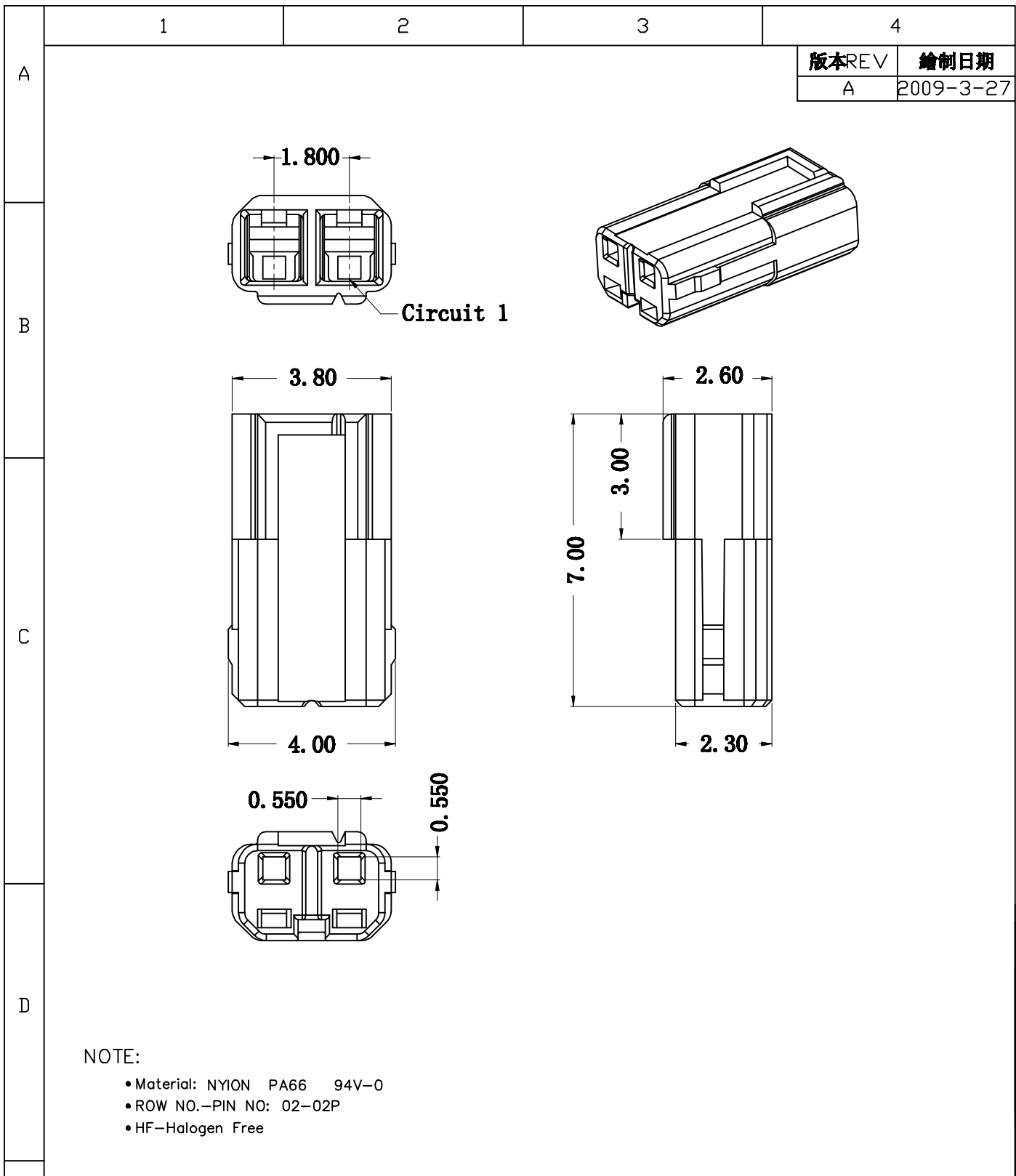

一般公差:GENERAL TOLERANCE		更改說明:REV.DESCRPTION			更改說明:REV.DESCRPTION	
尺寸範圍DIM		△			△	
10.01以上之尺寸	±0.30	△			△	
10.00以內之尺寸	±0.20	△			△	
孔位	±0.10	核准APPD	朱小华	2009-3-27	模型: MODEL	料號: ITEM NO
文件編號		審核CHD			A1801H-00-02	
SC-EW-11		繪圖DWN	Liaozting	2009-3-27		
比例: SCALE	 SHIH CHUAN ELECTRONICS				規格: SPEC 1.80mm Crimp Style Connectors	