

	1	2	3	4
--	---	---	---	---

版本REV	绘制日期
A1	2017-8-18

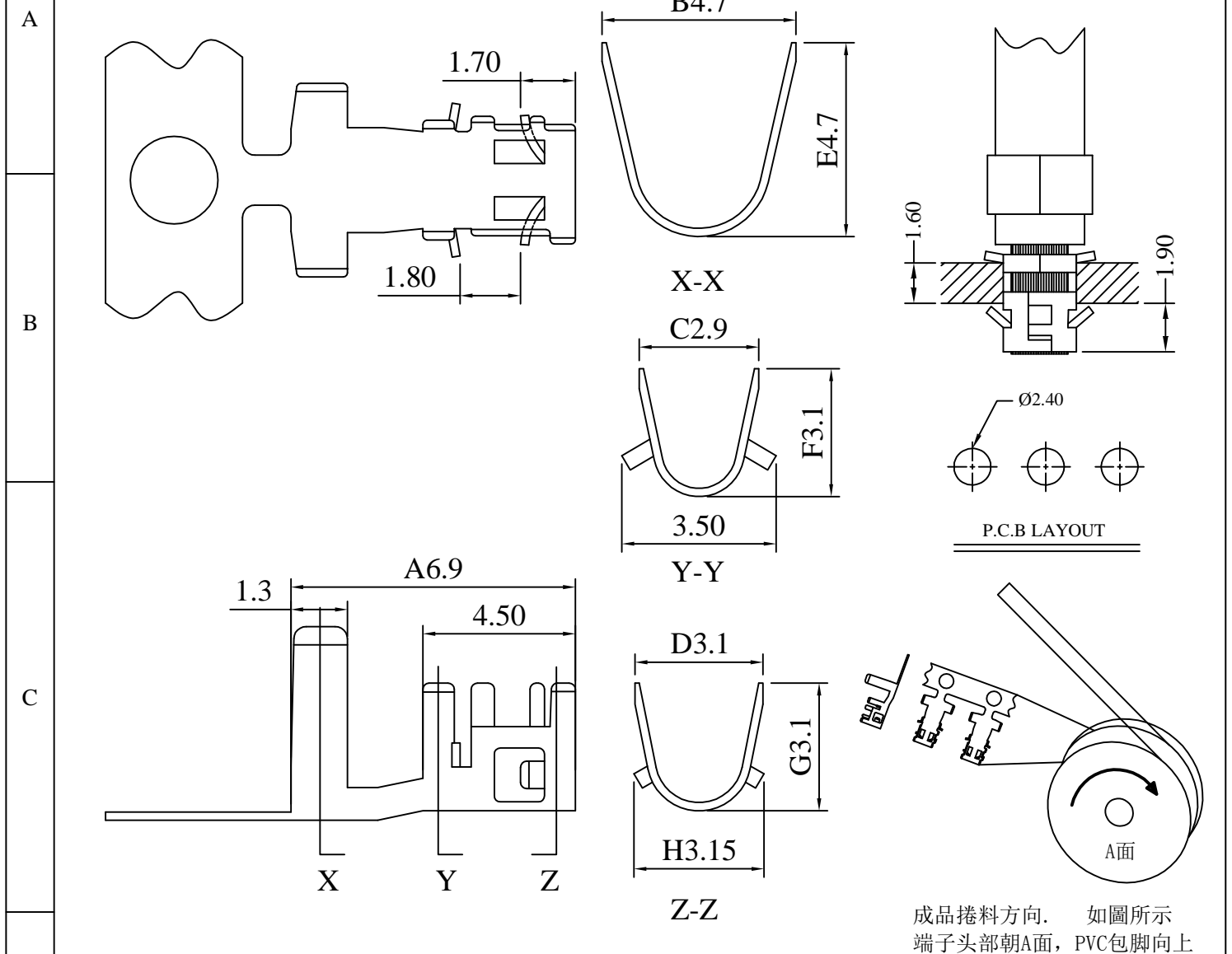

**NOTE:**

- 1.THICKNESS: 0.20mm
- 2.MATERIAL: PHOSPHOR BRONZE
- 3.FINISH: TIN-PLATE 60 μ "以上
- 4.APPLICABLE WIRE: AWG18x2

- 5.P.C.BOARD HOLE: 2.4Ø mm
- 6.P.C.BOARD THICKNESS: 1.60mm
- 7.STANDARD PACKING:4000PCS/R
- 8.此产品符合RoHS指令要求

D	NOTE:		5.P.C.BOARD HOLE: 2.4Ø mm		6.P.C.BOARD THICKNESS: 1.60mm		7.STANDARD PACKING:4000PCS/R		8.此产品符合RoHS指令要求	
---	-------	--	---------------------------	--	-------------------------------	--	------------------------------	--	-----------------	--

E	一般公差: GENERAL TOLERANCE		更改說明: REV.DESCRPTION			更改說明: REV.DESCRPTION				
	尺寸範圍DIM		①			④				
	.0	±0.20	②			⑤				
	.00	±0.15	③			⑥				
	.000	±0.10	核准APPD	朱小华	2017-8-18	模型:	料號: ITEM NO			
	文件編號		審核CHD	Tony	2017-8-18	MODEL	33093PS-2KH-T			
	SC-EW-11		繪圖DWN	廖政庭	2017-8-18					
比例: SCALE		 SHIH CHUAN ELECTRONICS				規格: SPEC				
						P.C.B2.4Ø				